

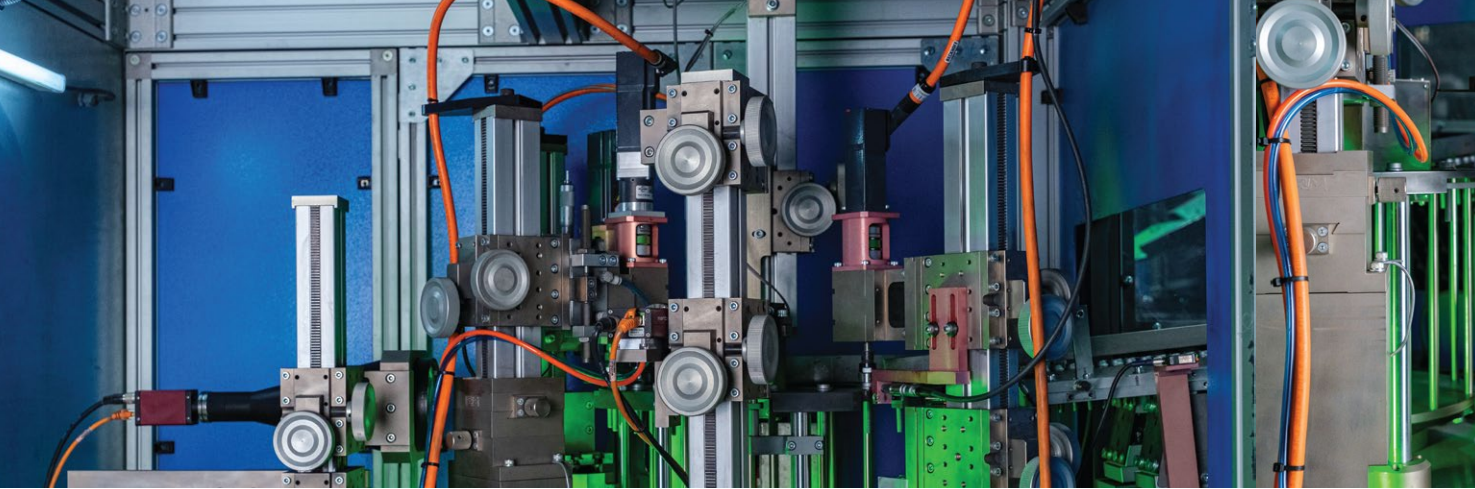

LEOPARD

BOLT INSPECTION MACHINE



WIDE PRODUCT RANGE

Bolts, cap pins, fittings, ball joints, and similar rotatable products can be checked. Working range for bolts

Diameter: M5-M16 Length: 16-150mm

HIGH CAPACITY

Depending on product specifications, capacity can reach 80-180 pcs/min.

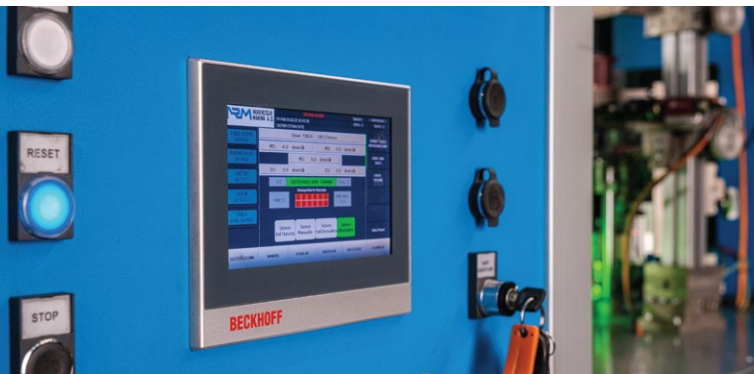

HIGH PRECISION

High resolution cameras and custom light design let 20 μ measurement precision depending on the measurement tools used.

RAPID MODEL CHANGE

The easy-to-use feedback interface and the manual mode option allow for fast model change.

CUSTOMIZED FUNCTION LIBRARIES

Flexible software design supports job customization. This feature allows function calls for different measurements or inspections. Most of the functions can be used for various purposes. Unlimited reference fixture points can be set to define ROIs properly.

Some of the defect types that can be inspected are listed below:

Flange diameter, head thickness, wrench form, thread pitch, thread angle, thread top diameter, shank diameter, dogpoint diameter, washer diameter, perpendicularity check, RSS check, bolt end angle, etc.

FLEXIBLE PLATFORM

Stations and their features can be changed depending on customer demand and product.

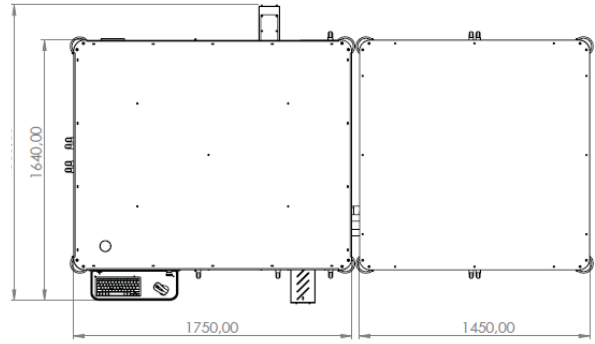
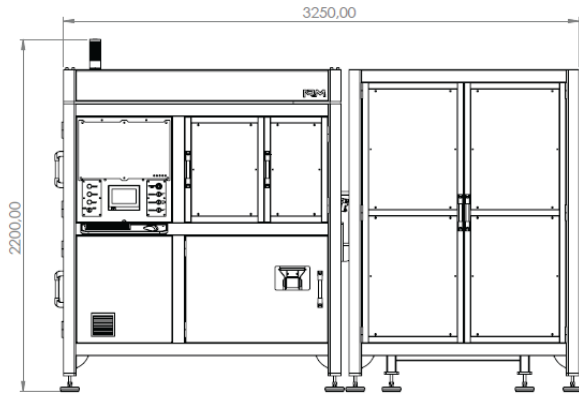

LEOPARD BOLT INSPECTION MACHINE

Weight	1200 kg
Machine Dimensions	2500 x 1350 x 2100 mm (width - length - height)
Capacity	80 -180 pcs/minute
Product Variety	Bolts, Pins, Rivets, etc
Types of Control	Crack, Structure test such as hardness (optional), Dimensional and Scrap
Operation Range	M5-M16 (shaft diameter) & 16-150 mm (shaft length)
Pre loading	Elevator, Linear or Bowl Vibrator
PLC Group	Beckhoff
Structure test and Crack Control	IBG Eddyguard tester /Optional
Dimension Control	4 High-resolution Optical Cameras
Precision	20 μ
Power	3,5 KVA
Curent (max)	10 A
Air Pressure	6 bar
Voltage Range	380 V- 3 Phase - 50 Hz
The dimensions that can be controlled for quality	Flange diameter, head thickness, wrench form, thread pitch, thread angle, thread top diameter, shank diameter, dogpoint diameter, washer diameter, perpendicularity, RSS check, bolt end angle, etc.

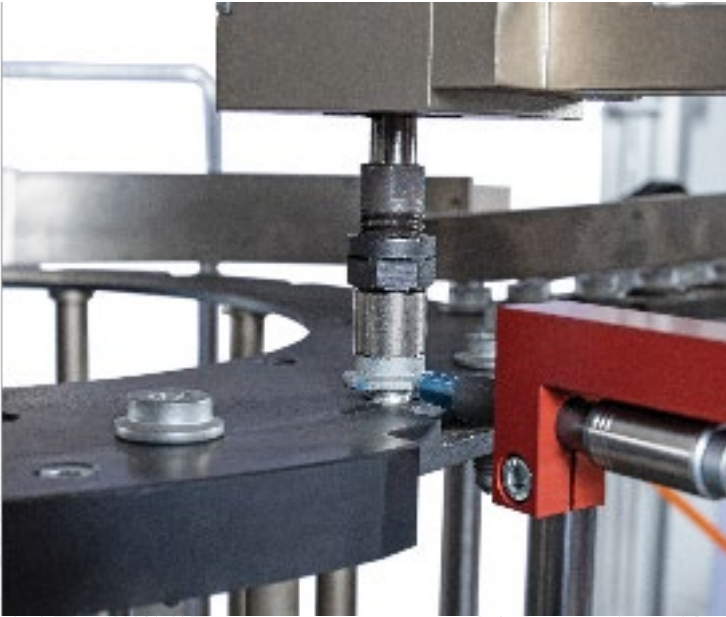
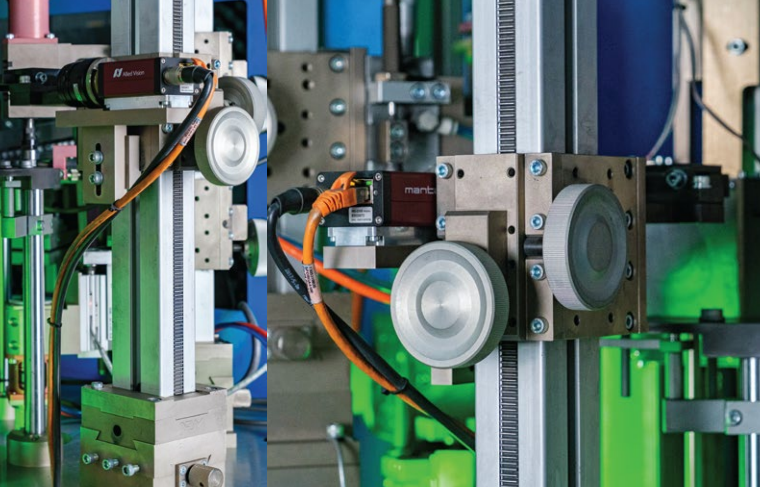

CONTACT US



Atatürk Organize Sanayi Bölgesi
10010 Sokak No: 21/1 Çiğli 35620 İzmir, Türkiye



+90 232 325 00 08



info@nrmmuhendislik.com.tr



www.nrmmuhendislik.com.tr



nrm-muhendislik